



User Manual

-Installation
-Operation

Omniksol-13k-TL
Omniksol-17k-TL
Omniksol-20k-TL

Omnik New Energy Co.,Ltd.

CATALOG

Catalog	3
1. Notes on this manual	5
1.1 General notes	5
1.2 Symbols Used	5
1.3 Target Group	6
2. Preparation	7
2.1 Safety Instructions	7
2.2 Explanations of Symbols on Inverter	9
3. Product Information	10
3.1 Overview	10
3.2 Major Characteristics	11
3.3 Technical Data	11
4. Packing checklist	13
4.1 Assembly parts	13
4.2 Product Appearance	14
4.3 Product Identification	16
4.4 Further Information	17
5. Installation	18
5.1 Safety	18
5.2 dimensions, weight	18
5.3 Mounting Instructions	19
5.4 Safety Clearance	20
5.5 Mounting Procedure	20
6. Electrical Connection	23
6.1 Safety	23
6.2 Overview of Connection Area	23
6.3 DC Side Connection	24
6.4 AC side connection	27
6.5 Communication and Monitoring connector	30

7.	Display	31
7.1	Main interface	31
7.2	LCD Display	32
7.3	State Information	46
8.	Monitoring system	48
9.	Recycling and Disposal	50
10.	Troubleshooting	51
11.	warranty	53
12.	Abbreviation	54
13.	Contact	55

1. NOTES ON THIS MANUAL

1.1 General notes

The main purpose of this User's Manual is to provide instructions and detailed procedures for installing, operating, maintaining, and troubleshooting the following three types of Omnik New Energy-Solar Inverters:

- Omniksol-13k-TL
- Omniksol-17k-TL
- Omniksol-20k-TL

Please keep this user manual all time available in case of emergency.

1.2 Symbols Used



DANGER

DANGER indicates a hazardous situation which, if not avoided, will result in death or serious injury.



WARNING

WARNING indicates a hazardous situation which, if not avoided, can result in death or serious injury or moderate injury.



CAUTION

CAUTION indicates a hazardous condition which, if not avoided, can result in minor or moderate injury.



NOTICE

NOTICE indicates a situation that can result in property damage, if not avoided.

1.3 Target Group

- Chapter 1, 2, 3, 4, 7, 8, 9, 10 and Chapter 11 are intended for anyone who is intended to use Omnik Grid Tie Solar Inverter. Before any further action, the operators must first read all safety regulations and be aware of the potential danger to operate high-voltage devices. Operators must also have a complete understanding of this device's features and functions.



WARNING

Do not use this product unless it has been successfully installed by qualified personnel in accordance with the instructions in Chapter 5, "Installation".

- Chapter 5 and Chapter 6 are only for qualified personnel who are intended to install or uninstall the Omnik Grid Tie Solar Inverter. Installation must be suitable to the on-site conditions and comply with local regulations and technical rules.



NOTICE

Hereby qualified personnel means he/she has the valid license from the local authority in:

- Installing electrical equipment and PV power systems (up to 1000 V).
- Applying all applicable installation codes.
- Analyzing and reducing the hazards involved in performing electrical work.
- Selecting and using Personal Protective Equipment (PPE).

2. PREPARATION

2.1 Safety Instructions



DANGER

DANGER due to electrical shock and high voltage

DO NOT touch the operating component of the inverter, it might result in burning or death.

TO prevent risk of electric shock during installation and maintenance, please make sure that all AC and DC terminals are plugged out.

DO NOT stay close to the instruments while there is severe weather conditions including storm, lighting etc.



WARNING

The installation, service, recycling and disposal of the inverters must be performed by qualified personnel only in compliance with national and local standards and regulations. Please contact your dealer to get the information of authorized repair facility for any maintenance or repairmen.

Any unauthorized actions including modification of product functionality of any form will affect the validation of warranty service; Omnik may deny the obligation of warranty service accordingly.



NOTICE

Public utility only

The PV inverter designed to feed AC power directly into the public utility power grid, do not connect AC output of the device to any private AC equipment.













CAUTION

The PV inverter will become hot during operation; please don't touch the heat sink or peripheral surface during or shortly after operation.

Risk of damage due to improper modifications.

Never modify or manipulate the inverter or other components of the system.

2.2 Explanations of Symbols on Inverter

Symbol	Description
	Dangerous electrical voltage This device is directly connected to public grid, thus all work to the inverter shall only be carried out by qualified personnel.
	DANGER to life due to high electrical voltage! There might be residual currents in inverter because of large capacitors. Wait 10 MINUTES before you remove the front lid.
	NOTICE, danger! This device directly connected with electricity generators and public grid.
	Danger of hot surface The components inside the inverter will release a log of heat during operation, DO NOT touch aluminum housing during operating.
	An error has occurred Please go to Chapter 10 “Trouble Shooting” to remedy the error.
	This device SHALL NOT be disposed of in residential waste Please go to Chapter 9 “Recycling and Disposal” for proper treatments.
	Without Transformer This inverter does not use transformer for the isolation function.
	German mark of conformity The inverter complies with the requirement of the German Grid Regulations.
	CE Mark Equipment with the CE mark fulfils the basic requirements of the Guideline Governing Low-Voltage and Electromagnetic Compatibility.
	No unauthorized perforations or modifications Any unauthorized perforations or modifications are strictly forbidden, if any defect or damage (device/person) is occurred, Omnik shall not take any responsibility for it.

3. PRODUCT INFORMATION

3.1 Overview

- Industrial Layout

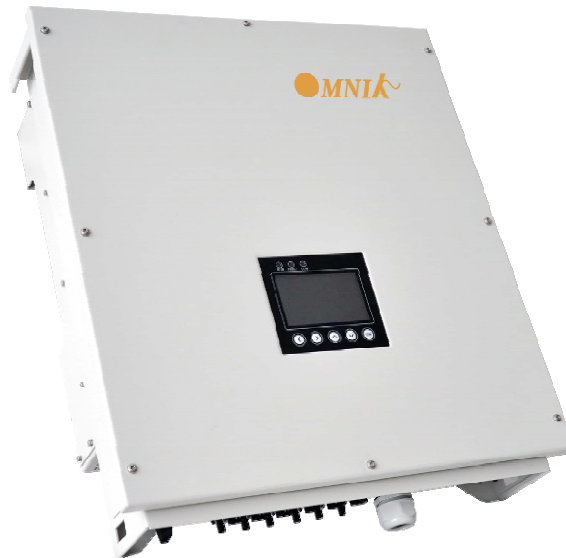

- Excellent Heat Elimination
- Effective Shield For DC/AC/Communication Connections



3.2 Major Characteristics

Omnik inverter has following characteristics which make Omnik inverter “High Efficiency, High Reliability, High Cost Effective Ratio”

- Comply with multiple safety regulation of European, Asia Pacific and Oceania countries.
- Double MPPT Tracking, MPPT tracking accuracy up to 99.9%.
- Max. Efficiency 98.2%, European Efficiency 97.8%.
- Professional radiating design, protection Level IP65, work properly under severe outdoor circumstances.
- Full solution of safety protection, DC switch integrated.
- Flexible input and output connections support RS485, Ethernet and USB communication.
- Transformer less design and high power density, it is lighter and more convenient for installation.

3.3 Technical Data

Type	Omniksol-13k-TL	Omniksol-17k-TL	Omniksol-20k-TL
Input(DC)			
Max.PV-Generator Power[W]	13500	17600	21200
Max DC Voltage[V]	1000	1000	1000
MPPT DC Volatage Range[V]	400-800	440-850	480-850
Nominal DC Voltage[V]	640	640	640
Turn off DC Voltage[V]	220	220	220
Turn on DC Voltage	250	250	250
Max.DC Current(A/B)[A]	22/11	22/22	22/22
Number of MPP Trackers	2	2	2
DC Connection per MPPT	A:3 / B:3	A:3 / B:3	A:3 / B:3
Output(AC)			
Nominal AC Voltage	3/N/PE,230/400V	3/N/PE,230/400V	3/N/PE,230/400V
Frequency[Hz]	50, 60	50, 60	50, 60
Grid Voltage Range	According to CE, VDE 0126-1-1, Enel-GUIDE, G59, AS4777, C10/C11, IEC 61727	According to CE, VDE 0126-1-1, Enel-GUIDE, G59, AS4777, C10/C11, IEC 61727	According to CE, VDE 0126-1-1, Enel-GUIDE, G59, AS4777, C10/C11, IEC 61727
Max. AC Power[W]	13000	17000	19200
Nominal AC Power[W]	13000	17000	19200
Nominal AC Current[A]	18,8	24.6	28
Max. AC Current[A]	20	26	29
Power Factor (cos)	0.9i ... 1 ... 0.9c	0.9i ... 1 ... 0.9c	0.9i ... 1 ... 0.9c
Harmonic Distortion(THD)	<2%	<2%	<2%
Power Consumption at Night[W]	<0.6	<0.6	<0.6

Power Consumption at Standby[W]	<12	<12	<12
Efficiency			
Max. Efficiency	98%	98,1%	98.2%
Euro Efficiency	97.5%	97.6%	97.8%
MPPT Efficiency	99.9%	99.9%	99.9%
Safety and Protection			
DC Surge Protection	Type III	Type III	Type III
DC Insulation Monitoring	Integrated	Integrated	Integrated
Earth Fault Protection	Integrated	Integrated	Integrated
Grid Monitoring	According to VDE 0126-1-1, RD1699, ENEL, G59, AS4777	According to VDE 0126-1-1, RD1699, ENEL, G59, AS4777	According to VDE 0126-1-1, RD1699, ENEL, G59, AS4777
Earth Fault Current Monitoring	According to VDE 0126-1-1, RD1699, ENEL, G59, AS4777	According to VDE 0126-1-1, RD1699, ENEL, G59, AS4777	According to VDE 0126-1-1, RD1699, ENEL, G59, AS4777
DC Current Monitoring	According to VDE 0126-1-1, RD1699, ENEL, G59, AS4777	According to VDE 0126-1-1, RD1699, ENEL, G59, AS4777	According to VDE 0126-1-1, RD1699, ENEL, G59, AS4777
Electricity Fuse Protection	Integrated	Integrated	Integrated
DC Switch	Integrated	Integrated	Integrated
DC Connection Monitoring	Integrated	Integrated	Integrated
Normative Reference			
CE Compliant According to	IEC62109,EN61000-6-2,EN61000-6-3, EN61000-3-12,EN61000-3-11	IEC62109,EN61000-6-2,EN61000-6-3, EN61000-3-12,EN61000-3-11	IEC62109,EN61000-6-2,EN61000-6-3, EN61000-3-12,EN61000-3-11
Device Data			
Dimension (WxHxD) [mm]	575x650x240	575x650x240	575x650x240
Weight[Kg]	44.5	45	45
Mounting Information	Wall Bracket	Wall Bracket	Wall Bracket
IP Protection Type	IP65 (EN 60529)	IP65 (EN 60529)	IP65 (EN 60529)
Cooling Concept	Convection and Fan cooling	Convection and Fan cooling	Convection and Fan cooling
Environmental Limits			
Operating Temperature Range[°C]	-20°C ~ 60°C	-20°C ~ 60°C (>55°C derating)	-20°C ~ 60°C (>45°C derating)
Relative Humidity	0% ~ 98%(no condensation)	0% ~ 98% (no condensation)	0% ~ 98% (no condensation)
Altitude[m]	0 ~ 2000m	0 ~ 2000m	0 ~ 2000m
Noise Level[dB]	<45dB (with fan<50dB)	<45dB (with fan<50dB)	<45dB (with fan<50dB)
Communication			
Monitoring Connection	RS485, Ethernet	RS485, Ethernet	RS485, Ethernet
Software Upgrade	RS232(USB)	RS232(USB)	RS232(USB)
LCD Display	800 x 480 TFT Graphic Display	800 x 480 TFT Graphic Display	800 x 480 TFT Graphic Display
Standard Warranty	5 years (Optional 10 years)	5 years (Optional 10 years)	5 years (Optional 10 years)

4. PACKING CHECKLIST

4.1 Assembly parts

After you receive the Omnik inverter, please check if there is any damage on the carton, and then check the inside completeness for any visible external damage on the inverter or any accessories. Contact your dealer if anything is damaged or missing. we will be glad to assist you if required.

			
A	B	C	D
			
E	F	G	H
			
I	J		

Object	Quantity	Description
A	1	Omnik inverter
B	1	Wall mounting bracket
C	1	user manual
D	4	Screw(ST6x50)
E	4	Expansion tube

F	1	AC cover
G	6	DC connector(6 x positive,6 x negative)
H	1	Ground nut (M6)
I	5	Cord end terminal
J	4	Screw (M4X12)

4.2 Product Appearance

- Front



Object	Description
A	LED light(Green) – RUN
B	LED light(Red) – FAULT
C	LED light(Yellow) – COM
D	< left choice
E	> Right choice
F	^ up choice
G	∨ down choice

H	Ok identify key
---	-----------------

- Bottom

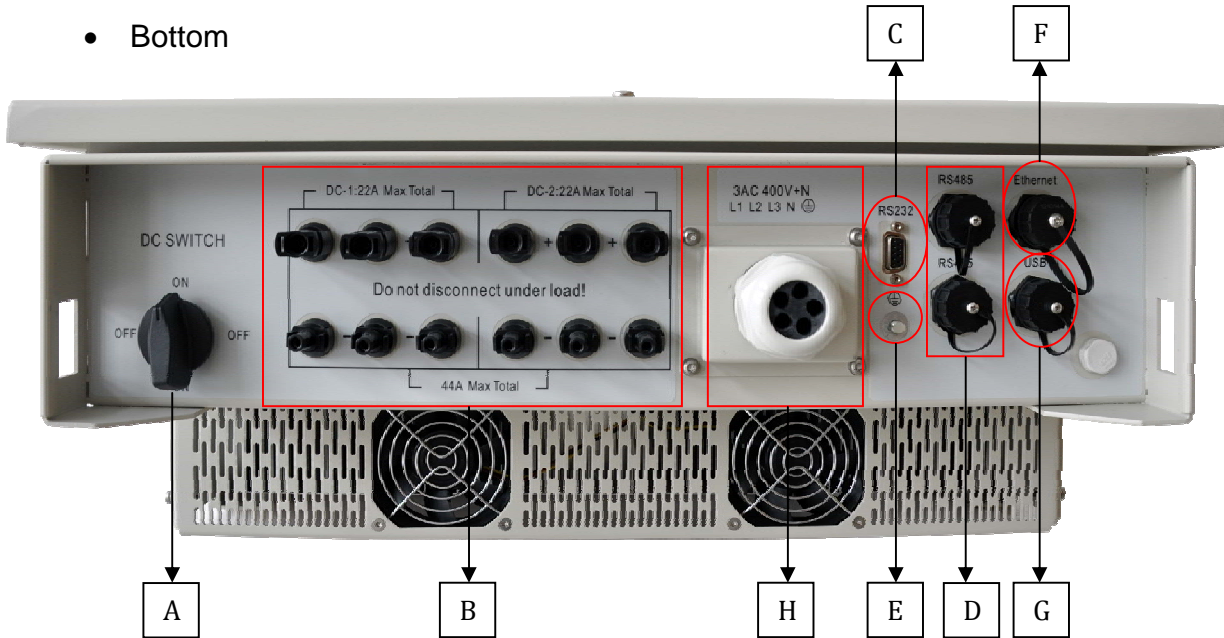

- Left and right

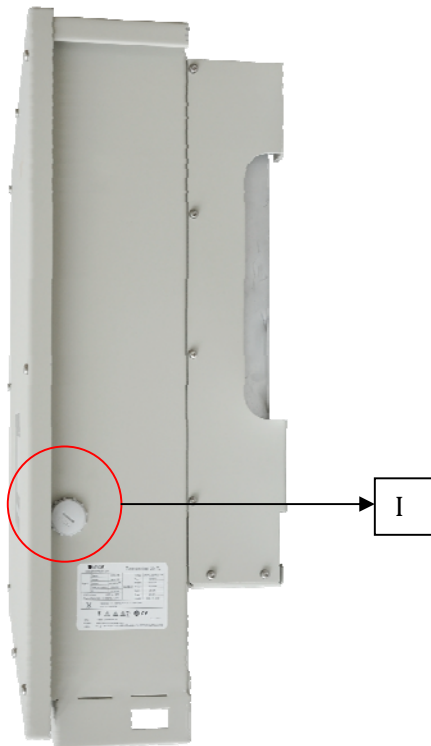

Object	Description
A	DC switch
B	Plug connectors for DC input.
C	RS232 interface
D	RS485 interface
E	Earthing
F	Ethernet interface
G	USB interface
H	Terminal for grid connection (AC output)
I	Update and reset switch for display





4.3 Product Identification

You can identify the inverter by the side nameplate. Information such as serial number (SN.), type of the inverter, as well as inverter specifications are specified on the side name plate. The name plate is on the middle part of the right side of the inverter housing. And the following figure is the side name plate example as on Omniksol-20k-TL.



www.omnik-solar.com

Type:Omniksol-20k-TL

Input	V_{max}:	1000V 	Output	V_{max}:	3/N/PE,230/400V 
	V_{nom}:	640V 		f_{nom}:	50/60Hz
	V_{MPP}:	480-850V 		P_{nom}:	19,200W
	I_{max}(String 1/2):	22A/22A		P_{max}:	19,200W
	P_{max}:	21,200W		I_{nom}:	28.0 A
IP 65,outdoor		-20°C to +60°C			
Over voltage Cat. : III [Mains], II [PV]				I_{max}:	29.0 A
				cos φ :	0.9i...1...0.9c



VDE0126-1-1, G59/2, AS4777.2/.3,RD1699,
C10/11,EN50438



TEL: +86 512 6956 8216

E-mail: service@omnik-solar.com

ADD: Xinghu Road No.218 bioBAY Park A4-314,215123 Suzhou China

Made in China

4.4 Further Information

If you have any further questions concerning the type of accessories or installation, please check our website www.omnik-solar.com or contact our service hotline.

5. INSTALLATION

5.1 Safety



DANGER

DANGER to life due to potential fire or electricity shock.

DO NOT install the inverter near any inflammable or explosive items.

This inverter will be directly connected with HIGH VOLTAGE power generation device, the installation must be performed by qualified personnel only in compliance with national and local standards and regulations.



NOTICE

NOTICE due to the inappropriate or the harmonized installation environment may jeopardize the life span of the inverter.

Installation directly expose under intensive sunshine is not recommended.

The installation site **MUST** have good ventilation condition.

5.2 dimensions, weight

Model	weight	Dimension (L×W×D)
Omniksol-13K-TL	44.5kg	575mm×650mm×240mm
Omniksol-17K-TL	45kg	575mm×650mm×240mm
Omniksol-20K-TL	45kg	575mm×650mm×240mm

5.3 Mounting Instructions

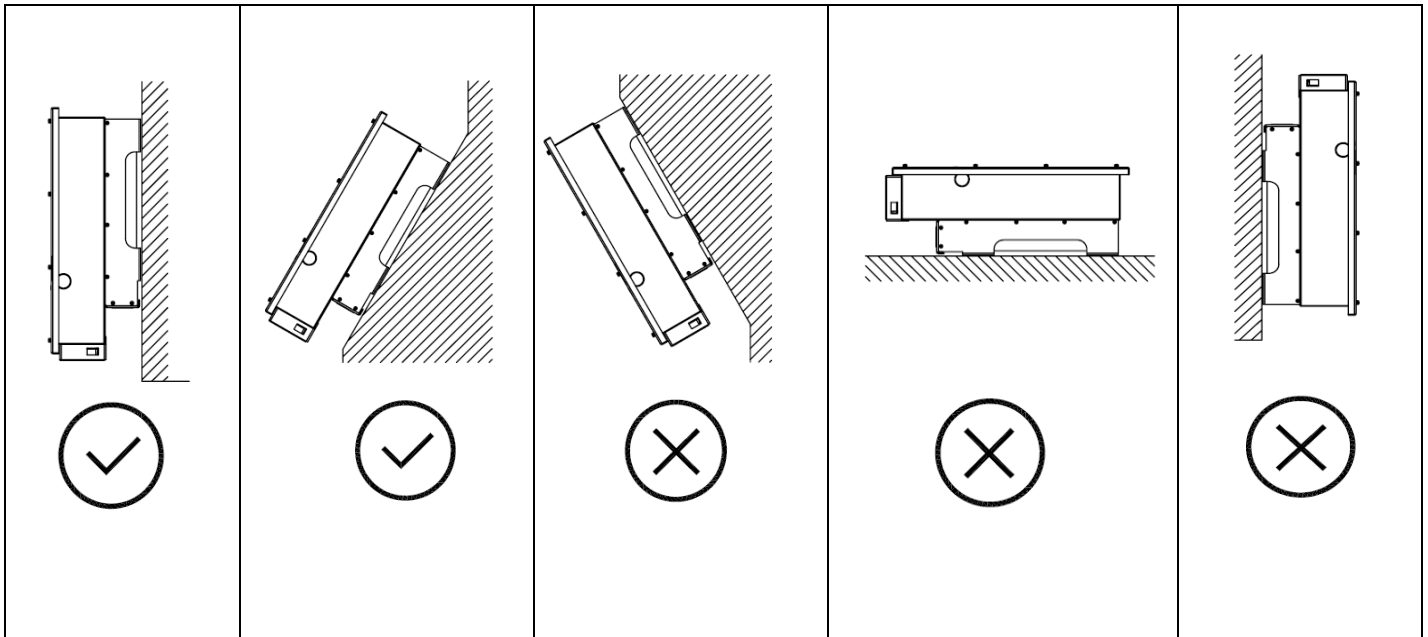

- Omnik inverter is designed for indoors and outdoors installation
- Please mount the inverter in the direction as illustrated above
- Install the inverter in the vertical direction is recommended, with a max.15 degrees backwards.
- For the convenience of checking the LCD display and possible maintenance activities, please install the inverter at eye level.
- Make sure the wall you selected is strong enough to handle the screws and bear the weight of the inverter
- Ensure the device is properly fixed to the wall
- It is not recommended that the inverter is exposed to the strong sunshine, because the excess heating might lead to power reduction
- The ambient temperature of installation site should be between -20 °C and +60 °C (between -4 °F and 140 °F)
- Make sure the ventilation of the installation spot, not sufficient ventilation may reduce the performance of the electronic components inside the inverter and shorten the life of the inverter

5.4 Safety Clearance

Observe the following minimum clearances to walls, other devices or objects to guarantee sufficient heat dissipation and enough space for pulling the electronic solar switch handle.

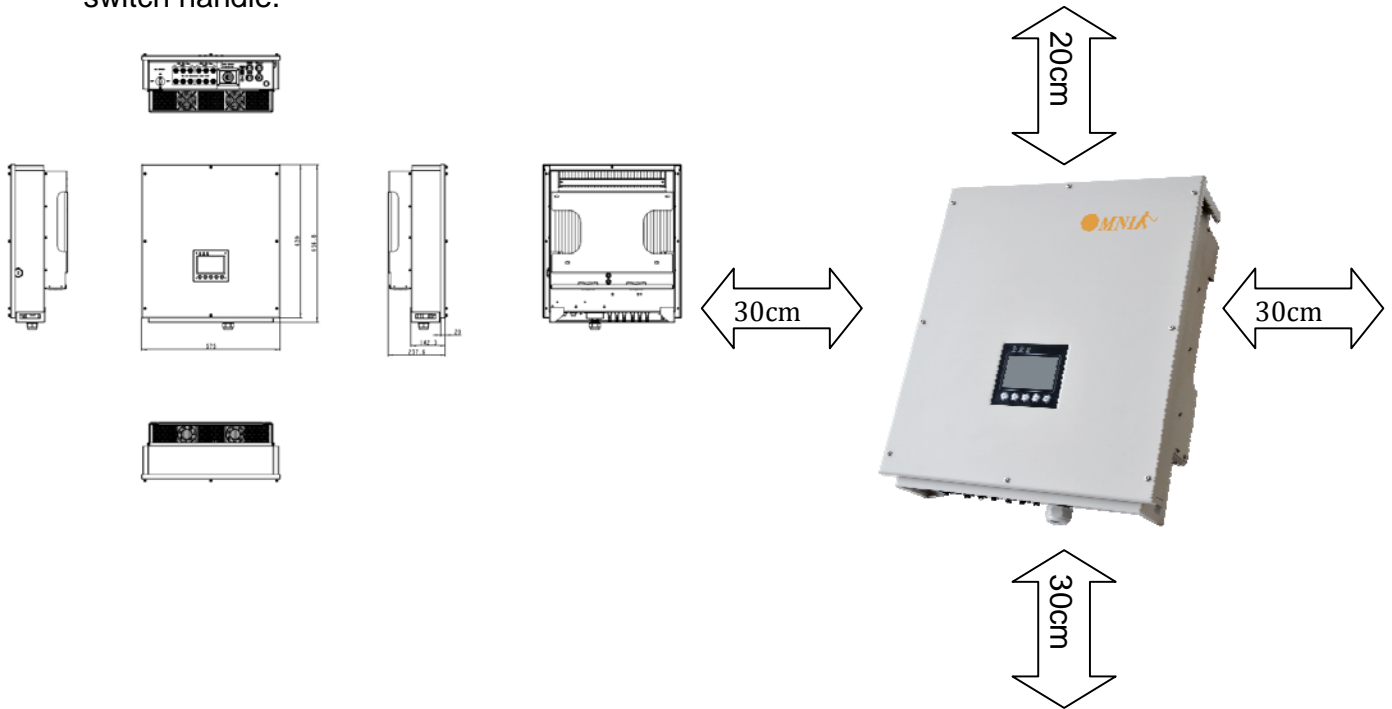

Direction	Minimum clearance
Above	20 cm
Below	30 cm
Sides	30 cm

5.5 Mounting Procedure

1. Mark 4 positions of the drill holes on the wall according to the paper installation position scale packed in the carton box.

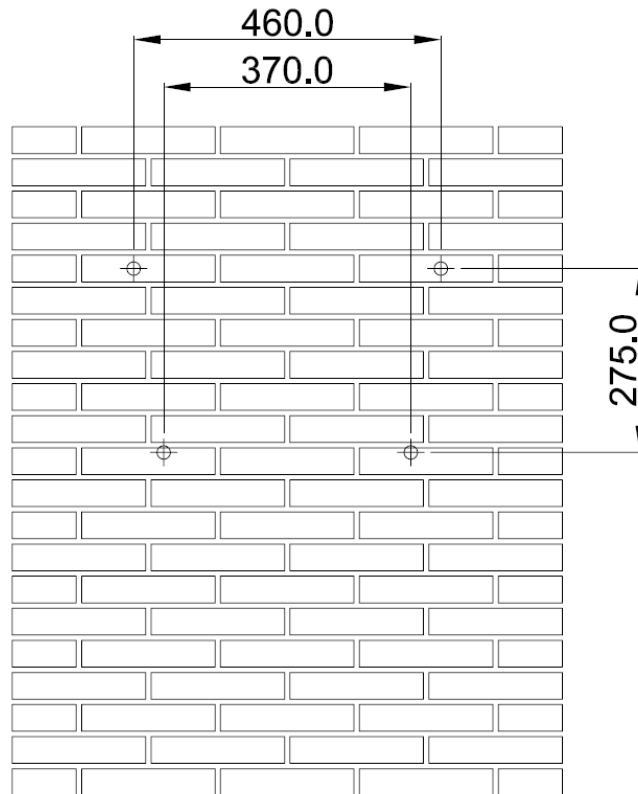

2. First, according to the marks, drill 4 holes in the wall. Then, place four expansion tubes in the holes using a rubber hammer. Next, wring 4 screws into the expansion tubes.

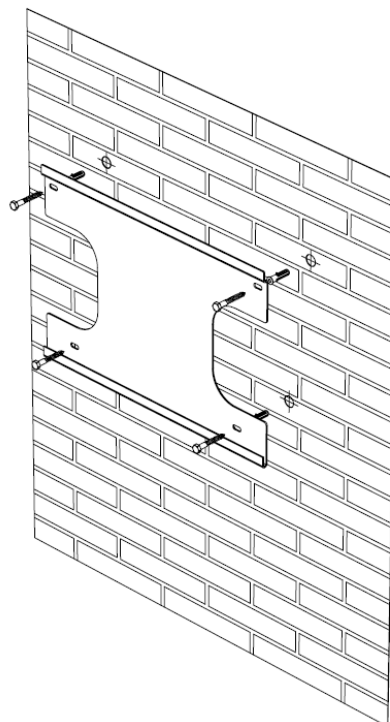

3. First check the 4 holes in the backside of the inverter. Then, lift the inverter carefully, align the 4 holes in the inverter and the 4 screws in the wall, and finally attach the inverter to the screws slightly.

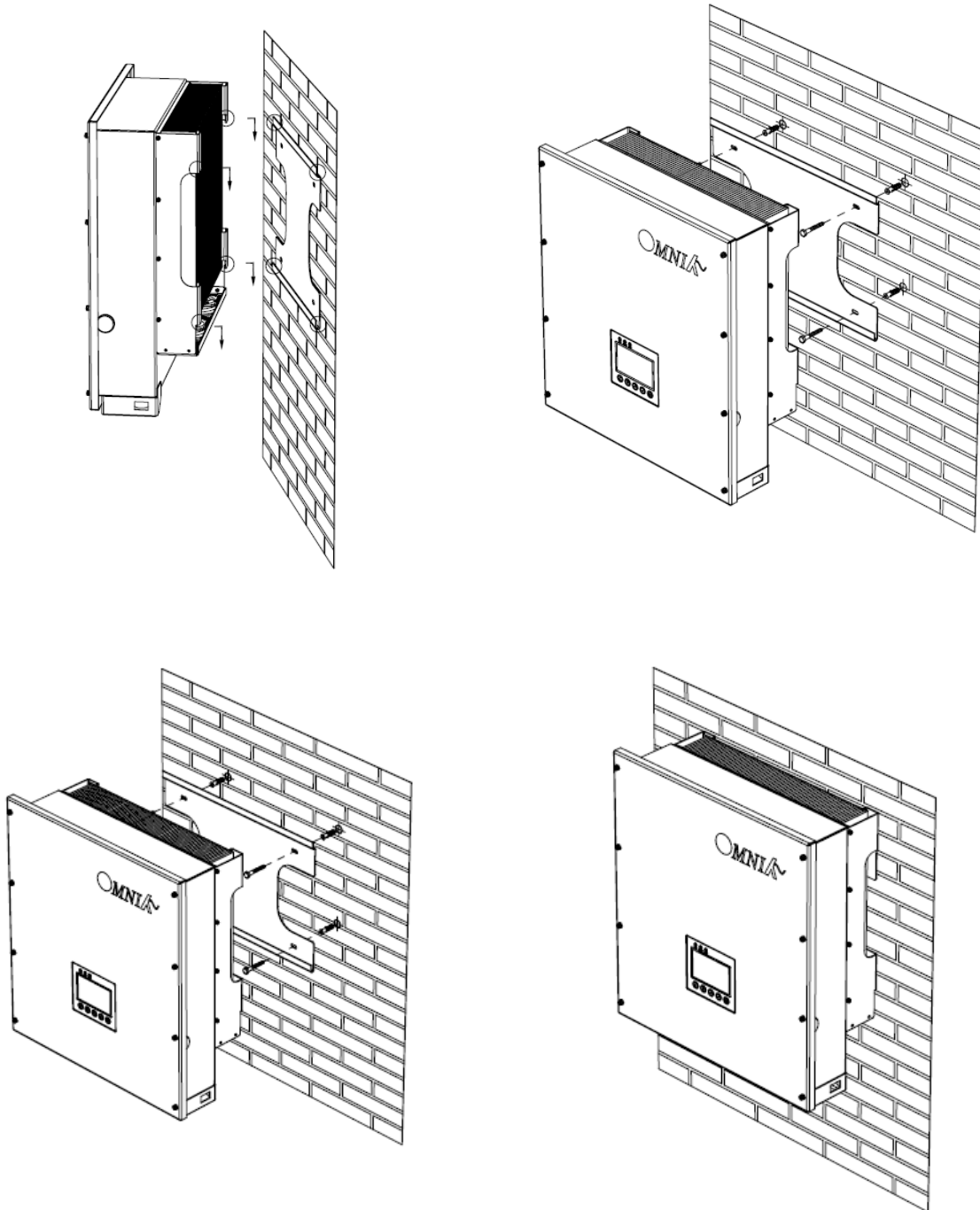

4. Please carefully check the accessories and original carton to make sure every necessary part is used and nothing is missing during installation.

6. ELECTRICAL CONNECTION

6.1 Safety



DANGER

DANGER to life due to potential fire or electricity shock. With the inverter powered, comply with all prevailing national regulations on accidents prevention. This inverter will be directly connected with HIGH VOLTAGE power generation device, the installation must be performed by qualified personnel only in compliance with national and local standards and regulations.



NOTICE

Electrical connections shall be carried out in accordance with the applicable regulations, such as conductor sections, fuses, PE connection.

6.2 Overview of Connection Area

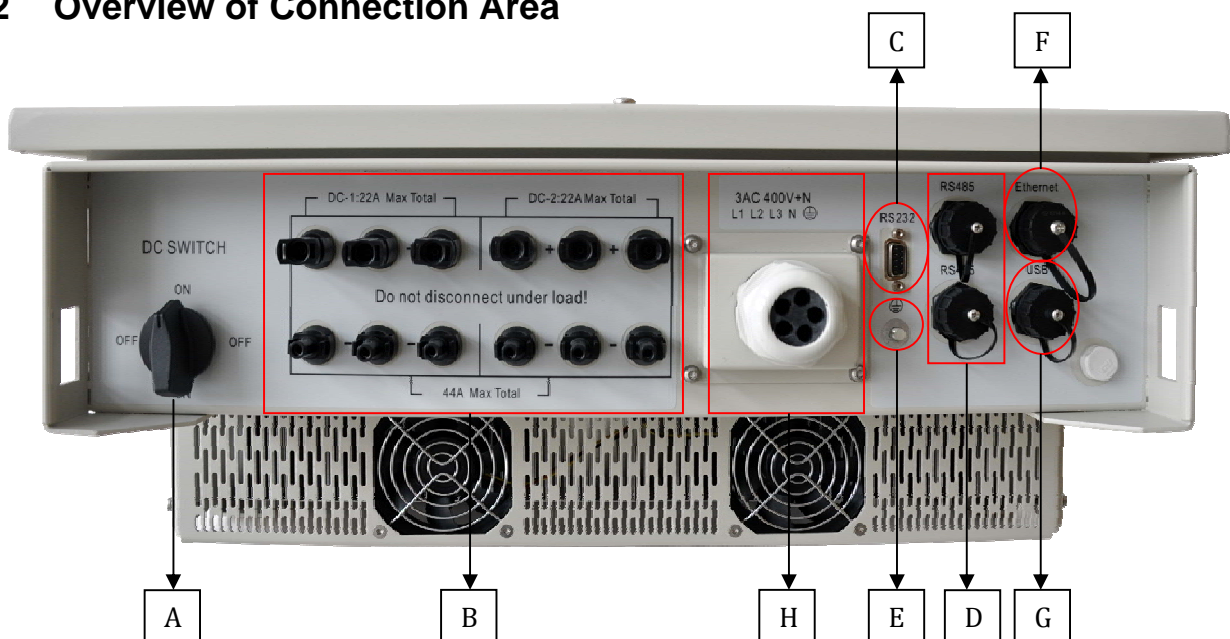

Object	Description
A	DC switch
B	Plug connectors for DC input.
C	RS232 interface
D	RS485 interface
E	Earthing
F	Ethernet interface
G	USB interface
H	Terminal for grid connection (AC output)

6.3 DC Side Connection



DANGER

DANGER to life due to potential fire or electricity shock.

NEVER connect or disconnect the connectors under load.



NOTICE

DC Switch (**Optional**) may be integrated or external to Inverter, and it can be used to connect or disconnect the DC source from Inverter.

For Omniksol-13k-TL , Omniksol-17k-TL and Omniksol-20k-TL, there are two MPP Tracker, and the DC characteristics of them are illustrated as the following table.

Inverter Type	MPP Tracker	Max. DC Power	Max. DC Voltage	Max. DC Current
Omniksol-13k-TL	2	13500W	1000V	22/11A
Omniksol-17k-TL		17600W		22/22A
Omniksol-20k-TL		21200W		22/22A

Connection procedure by MC4:

Connect the PV modules and inverter using MC4 connectors below. Connect the positive and negative terminals from the PV modules to positive (+) terminals and negative (-) terminals on Omniksol.

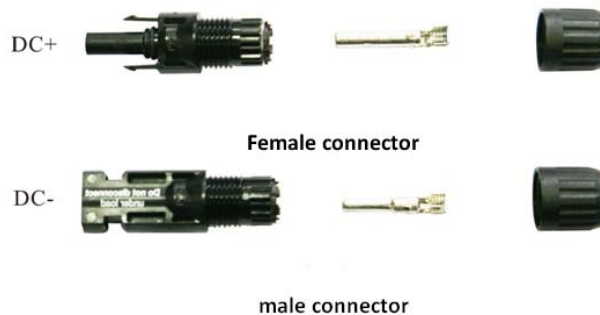

Connection Procedure:

1. Switch off the DC breaker and secure against being switched back on inadvertently.
2. Strip the cable 7 mm.



3. Insert striped cable into contact barrel and insure all conductor strands are captured in the contact barrel.
4. Crimp contact barrel by using a hex crimping die. Put the contact barrel with striped cable in the corresponding crimping notch and crimp the contact.



5. Insert contact cable assembly into back of the male and female connector. A “click” should be heard or felt when the contact cable assembly is seated correctly.



6. Wrest the cap by using the torque of 2.6~2.9NM.



7. After wrest the cap tightly, align the 2 half connectors and mate them together by hand until a “click” is heard or felt.



8. When the separation of connector is necessary, use the specified wrench tool to separate. Please make sure the wedge side of the fingers face the male connector and push the tool down. Then separate the connector by hand. See below figure.



9. If input connector is not enough, adopt “Y” connector (optional) just as below:



10. Please use sealing caps for tight sealing of unplugged PV connectors.



If using H4 connector, the operating procedure is similar as that of MC4 connector.

6.4 AC side connection



DANGER

DANGER to life due to potential fire or electricity shock.

NEVER connect or disconnect the connectors under load.



NOTICE

DC Switch (**Optional**) may be integrated or external to Inverter, and it can be used to connect or disconnect the DC source from Inverter.

Connection Procedure

1. Strip the cable 12mm



2. Insert the striped cable into cord end terminal and insert the assembly into barrel.

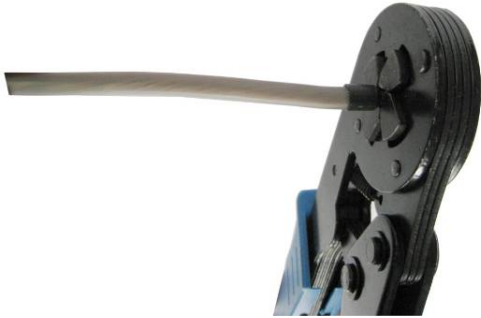

Then the line will like the picture belows.



3. Insert the finished 5 lines into AC cover assembly with the following sequence:



Open the plastic cover, use slot type screwdriver to press the shrapnel in the indicated position, and then put the line in the right hole, please note the sequence of the line shall in the right order: L1,L2,L3,N,PE

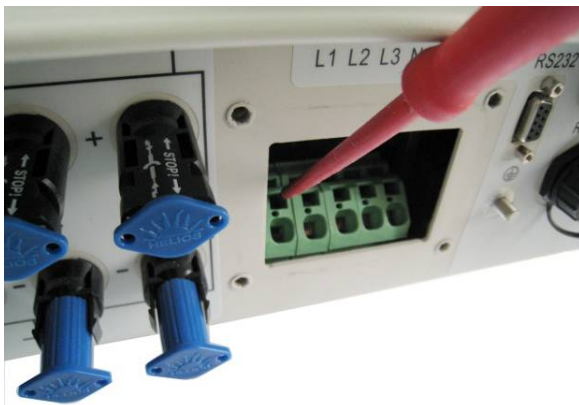



Cover the assembly, tightly screwed and then screw the cable gland



6.5 Communication and Monitoring connector

There are RS232/RS485, Ethernet and USB interface in the bottom side of the Omnik inverter as the following figure:

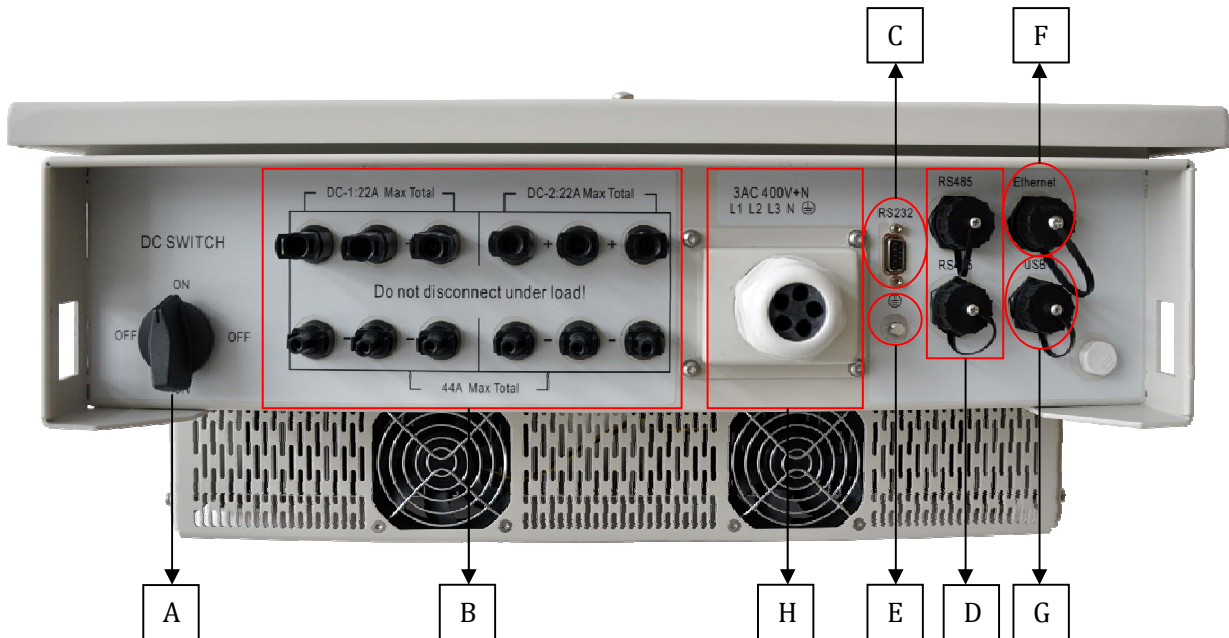

The function is as below:



Object	Description	Function
C	RS232 interface	Update the Software Version of the inverter
D	RS485 interface	Connect with PMB
F	Ethernet interface	Connect with Ethernet
G	USB interface	Connect with USB
I	Display interface	Update and reset switch for display

7. DISPLAY

7.1 Main interface

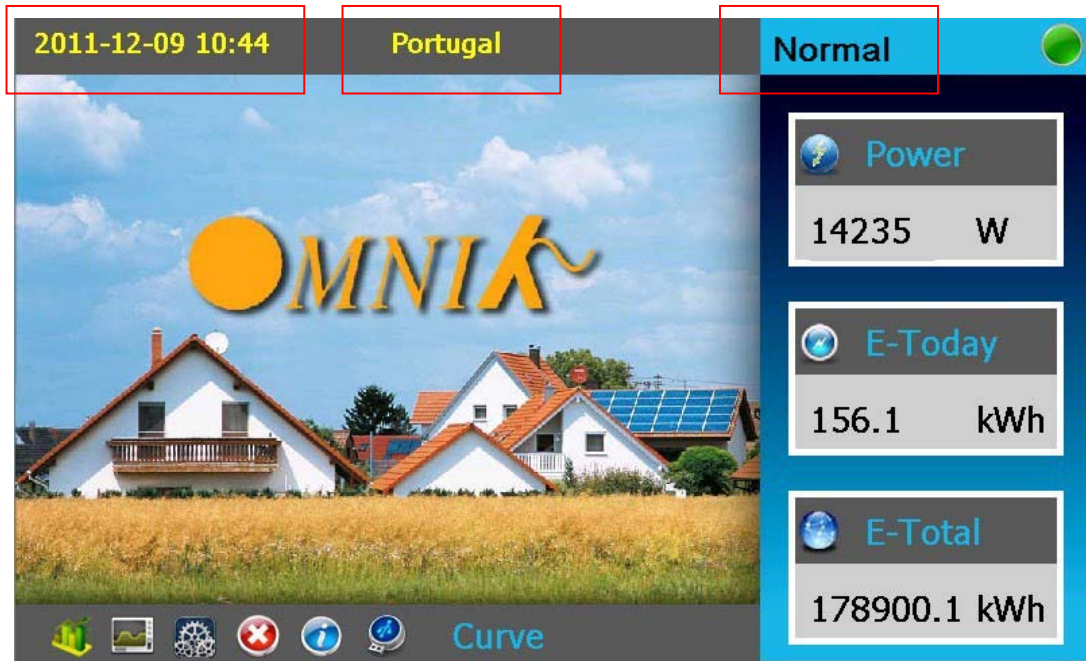

Object	Description
Time (e.g.2011-12-09 10:44)	Current date and time
Safety(e.g. Portugal)	Current safety regulation selected
Operation (e.g. normal)	Current operation condition
E-today	The energy generated today in kilo watt hours (kWh)
E-total	The energy generated since starting up the inverter (kWh)

The LCD panel is integrated in the front lid of the inverter, so it is easy for user to check and set the data. In addition, the user can press the function key to illuminate the LCD screen.



NOTICE

Omnik inverter is not an aligned measuring instrument for current, voltage or power consumption. A slight deviation of a few percent points is intrinsic to the system, the results from the inverter cannot be used for grid balance calculations. An aligned meter will be required to make calculations for the utility company.

7.2 LCD Display

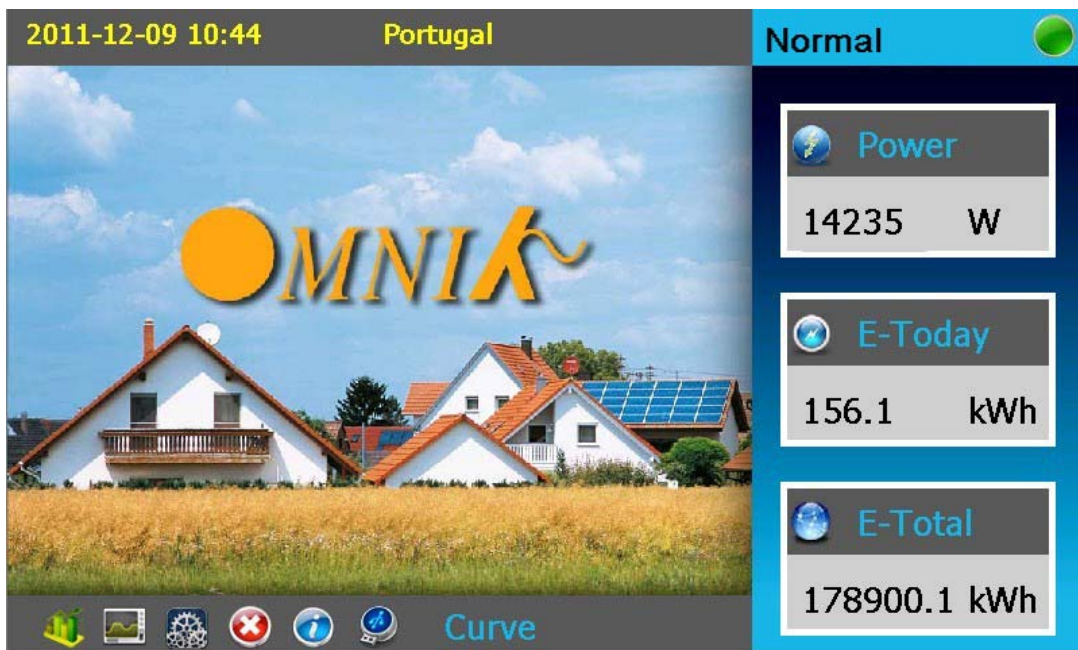

7.2.1. Curve

1.1 P-Now

Draw curve of current power:

Click "Curve"----"P-Now"

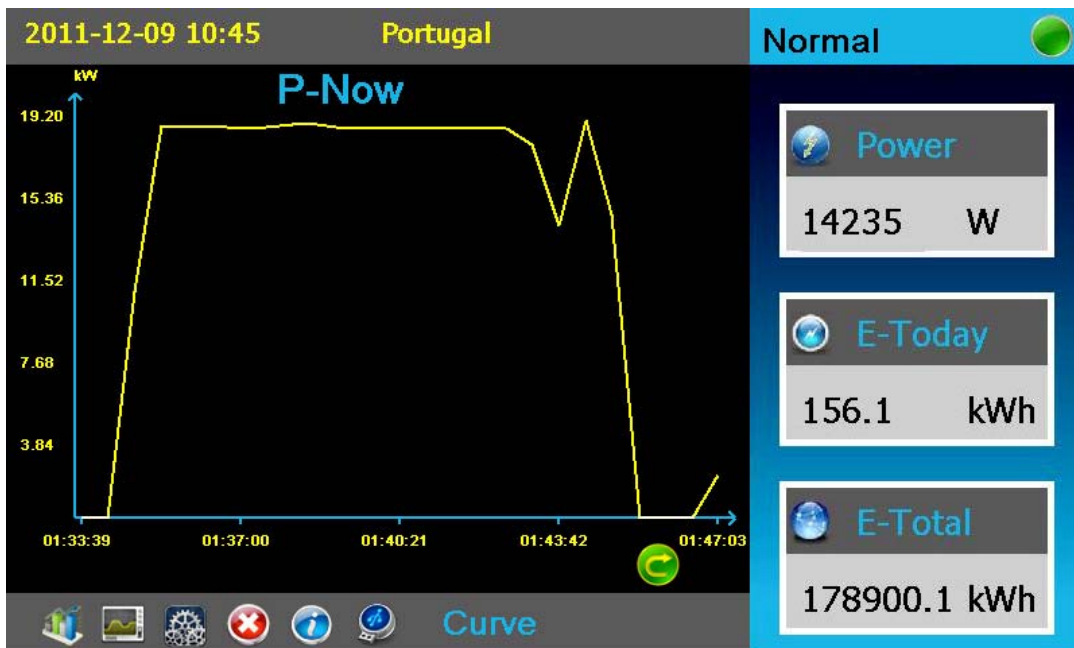

1.2 P-Day

Draw curve of one day's power:

Click "Curve"----"P-Day"

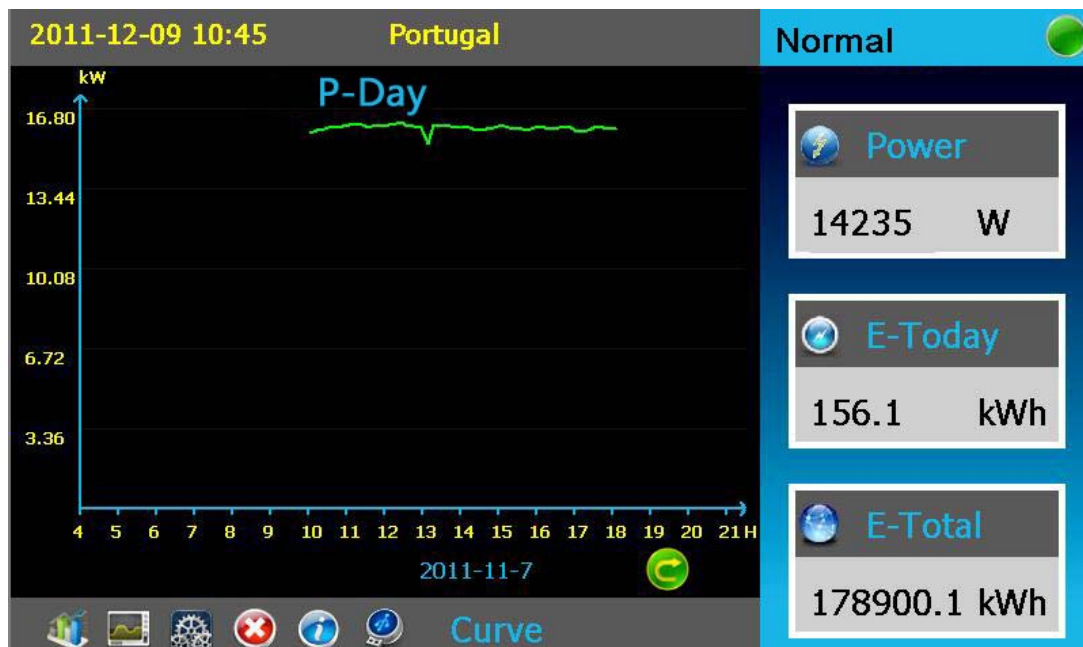
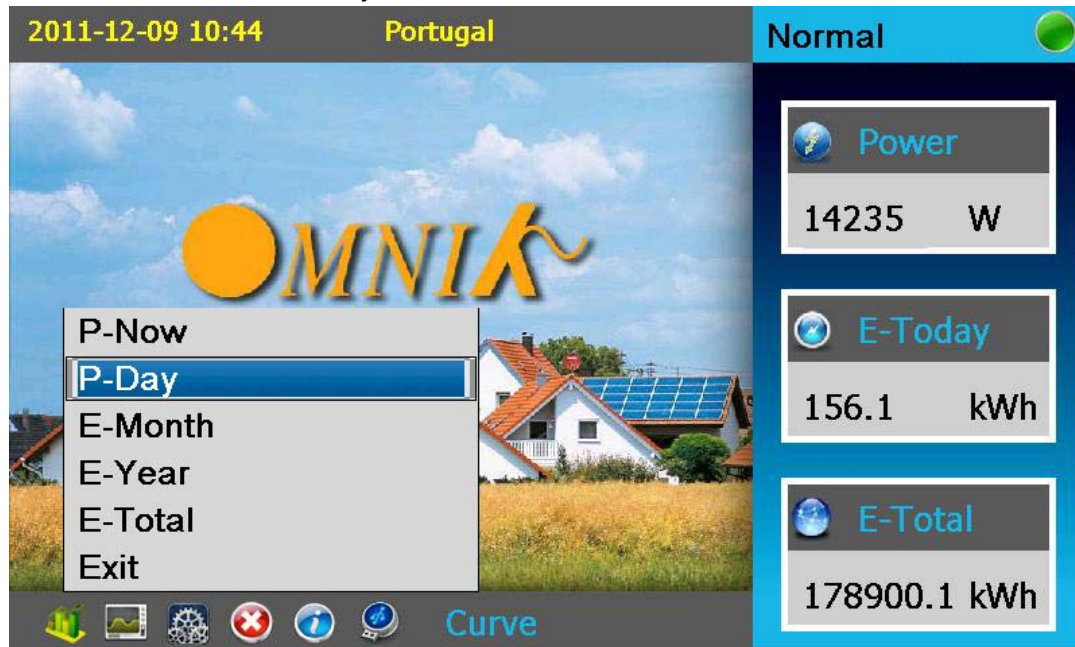

1.3 E-Month

Show one month's generated energy:

Click "Curve" ---- "E-Month"

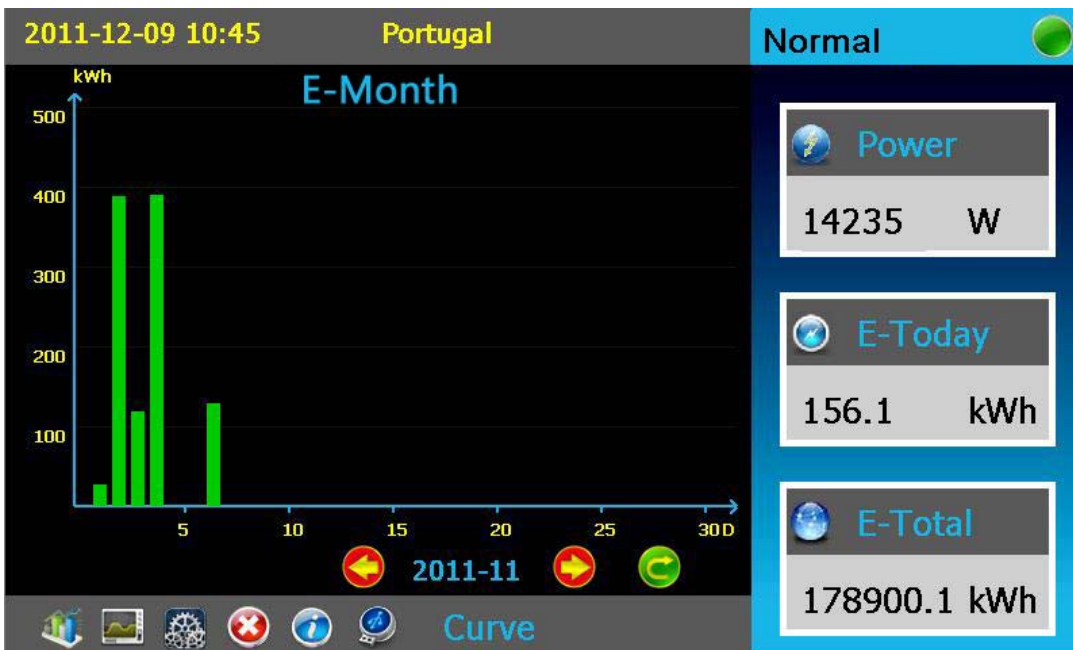
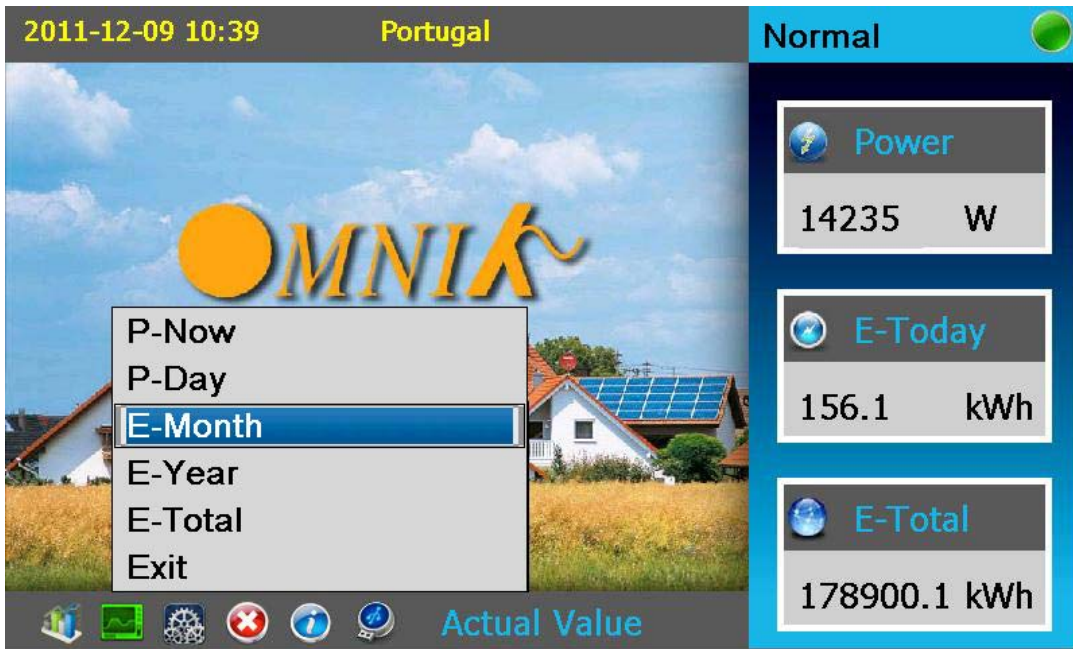

1.4 E-Year

Draw curve of one year's generated energy:

Click "Curve"----"E-Year"



1.5 E-Total

Draw curve of every year's generated energy:
Click "Curve"----"E-Total"

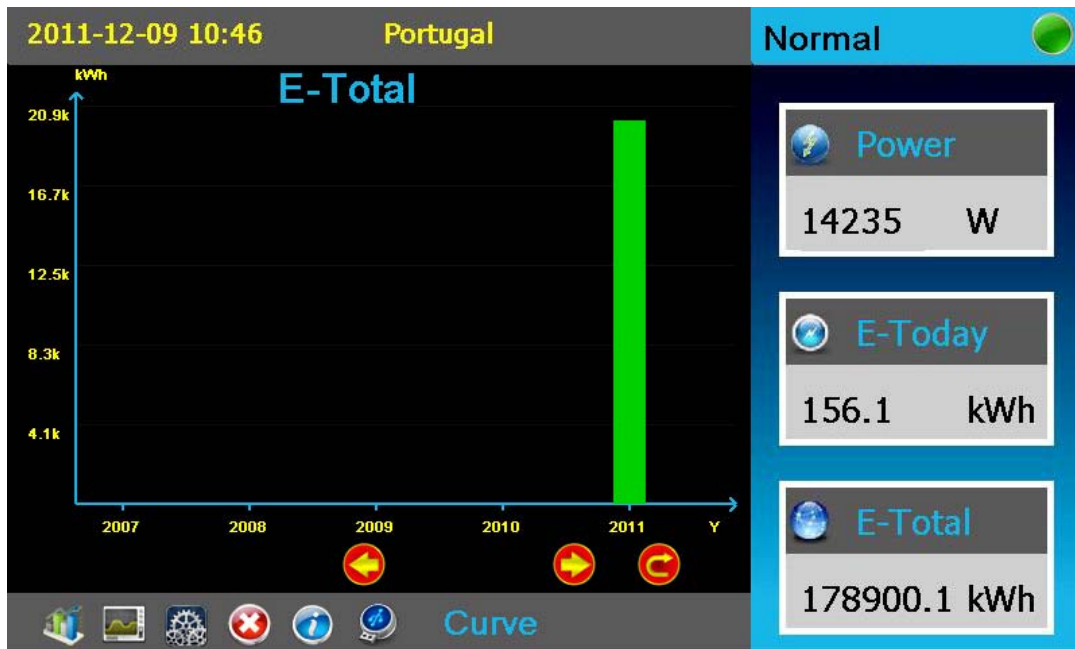

7.2.2. Parameters

2.1 AC Parameters

Show AC parameter:

Click "Actual Value"---"AC Actual Value"

2011-12-09 10:39 Portugal Normal

Power
14235 W

E-Today
156.1 kWh

E-Total
178900.1 kWh

AC Actual Value
DC Actual Value
Sensor Actual Value
Exit

Actual Value

2011-12-09 10:53 Portugal Normal

Safety Parameters

Safety Portugal

Vpv-Start 0.0 V T-Start 0 Sec

Fac-Min 0.00 Hz Fac-Max 0.00 Hz

Vac-Min 0.0 v Vac-Max 0.0 v

Apply Default Return

Power
14235 W

E-Today
156.1 kWh

E-Total
178900.1 kWh

Setting

2.2 DC Parameters

Show DC parameter, including following items:

Vpv (1-2), Ipv(1-2)

Click “Actual Value” --- “DC Actual Value”



2011-12-09 10:39 Portugal Normal

Power: 14235 W
E-Today: 156.1 kWh
E-Total: 178900.1 kWh

AC Actual Value
DC Actual Value
Sensor Actual Value
Exit

Actual Value

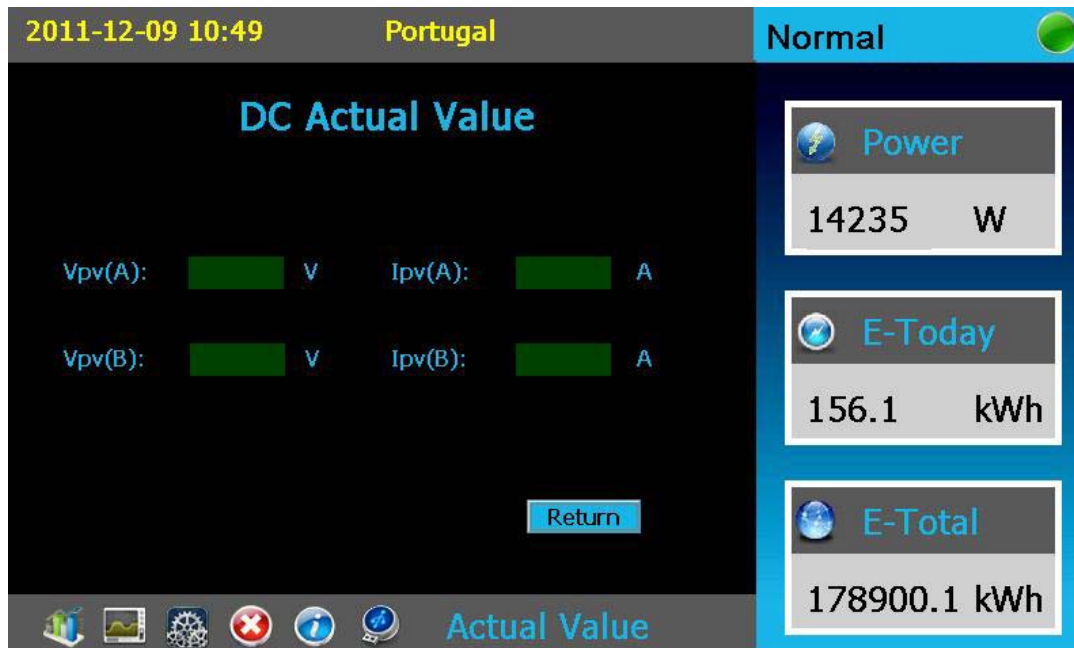

2011-12-09 10:49 Portugal Normal

DC Actual Value

Vpv(A): [] V Ipv(A): [] A
Vpv(B): [] V Ipv(B): [] A

Return

Power: 14235 W
E-Today: 156.1 kWh
E-Total: 178900.1 kWh

Actual Value

7.2.3. Tools & Options

3.1 Language and Time

Setting of language & time

Click “Setting” ----“Language and Time”

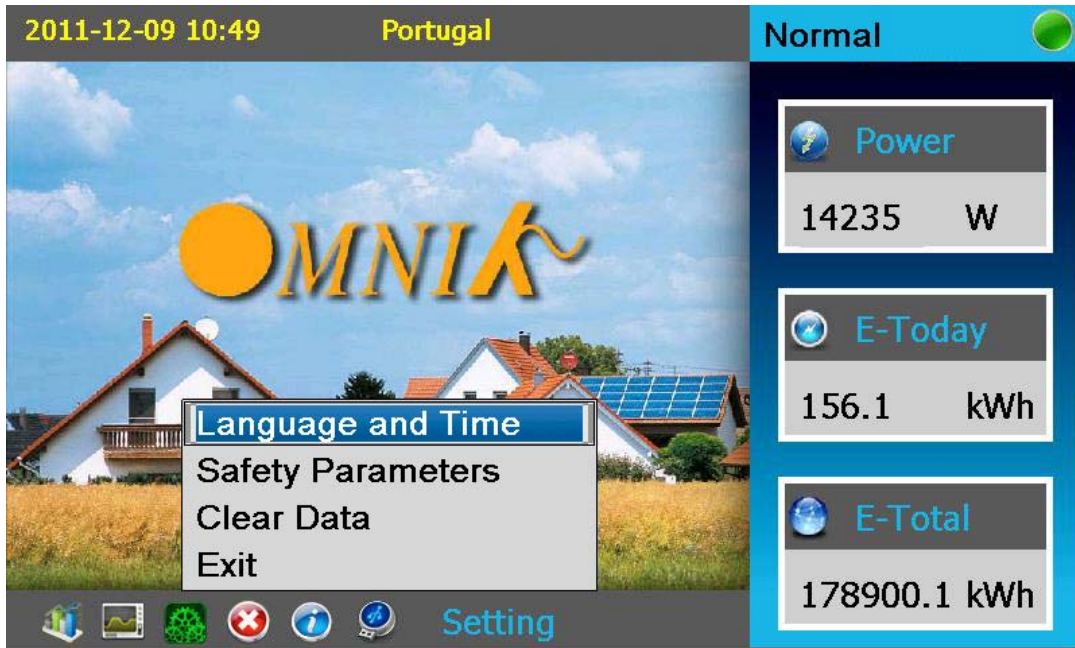

3.2 Safety Parameters

Setting of safety parameters:

Click “Setting” ----“Safety Parameters”。

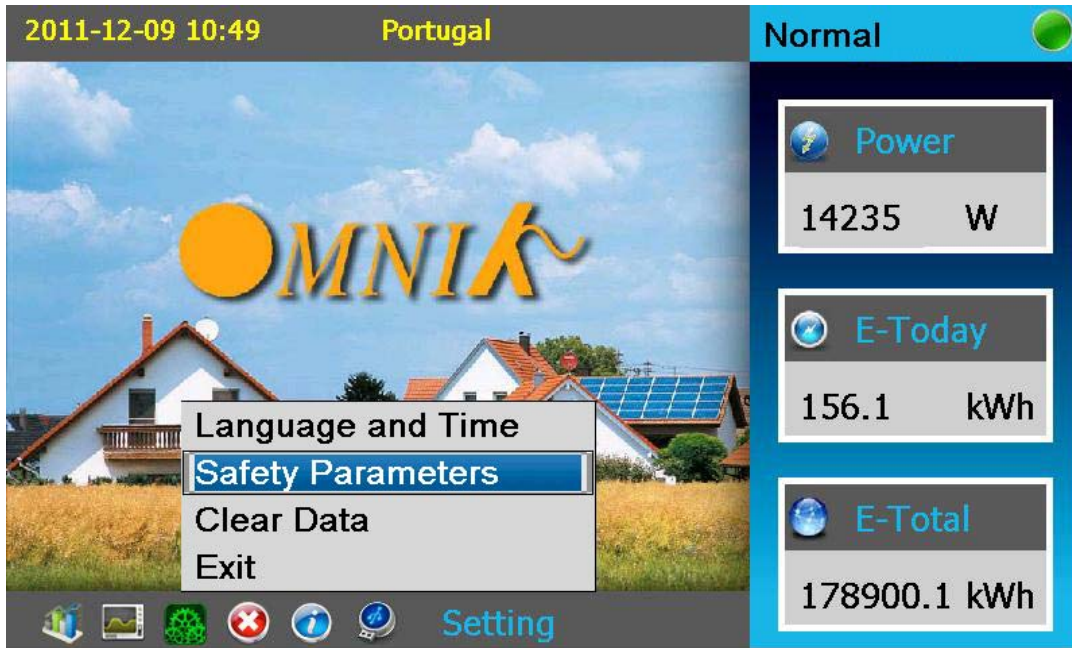



3.3 Clear Data

Clear Log:

Click "Setting" ----"Clear Data"

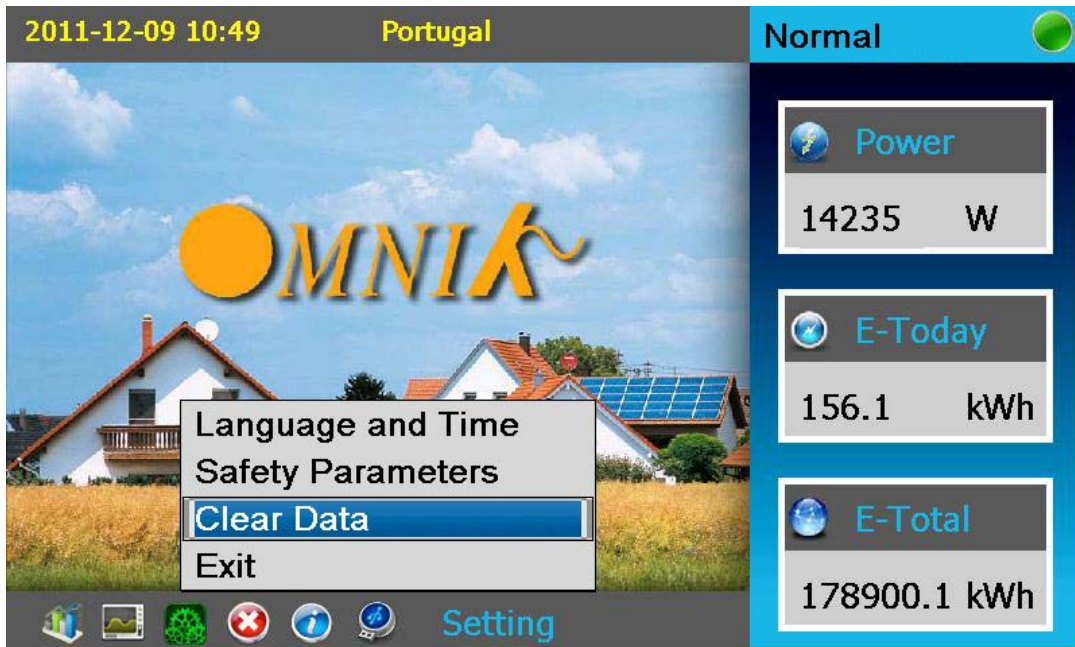

2011-12-09 10:54 Portugal Normal

Verify
Please enter your password!

0 0 0 0

Ok Return

Power
14235 W

E-Today
156.1 kWh

E-Total
178900.1 kWh

Setting

2011-12-09 10:55 Portugal Normal

Clear Data

Attention: If you click the button "OK", all the datas such as E-Today, E-Total, and some other datas saved in the inverter will be permanently deleted, so before the operation, please backup all the datas.

Ok Return

Power
14235 W

E-Today
156.1 kWh

E-Total
178900.1 kWh

Setting

7.2.4. Information

4.1 Device Info

Kinds of inverter: 20K/17K/13K

Vision number & serial number:

Click “Information” ---- “Device Info”

2011-12-09 10:58 Portugal Normal

Power: 14235 W
E-Today: 156.1 kWh
E-Total: 178900.1 kWh

Device Info
Exit

Information

The screenshot shows a main dashboard with a background image of houses and solar panels. The 'OMNIA' logo is prominently displayed. A menu box is open, showing 'Device Info' and 'Exit' options. The right sidebar contains three data cards for Power, E-Today, and E-Total. The bottom navigation bar includes several icons and the word 'Information'.

2011-12-09 10:58 Portugal Normal

Device Informations

Device Type: Omnisol-20k-TL
SN.
HMI SW.: V1.1.2 Build:0332
CU SW.: Master:V1.0.6 Build:0039
Slave :V1.0.6 Build:0014

Return

Power: 14235 W
E-Today: 156.1 kWh
E-Total: 178900.1 kWh

Information

This screenshot displays the 'Device Informations' screen. It lists various device parameters such as Device Type, SN, HMI SW., and CU SW. with their respective values. A 'Return' button is visible at the bottom of the main content area. The right sidebar and bottom navigation bar are identical to the previous screenshot.

7.2.5. Error

5.1 Error Info

Show Error information:

Click “Error” ---- “Error Info”



7.2.6. Update

6.1Flash

It's used for updating invertors' Firmware. After putting invertor's ROM documents to related catalogue, users can update the Firmware by clicking the button.

7.3 State Information

State	Display	State information
Wait	Waiting	Initialization & waiting
	Connect Sec.	Connect
Normal	Normal	Normal state
Fault	SPI Failure:Communication Fails between M-S	SPI Failure:Communication Fails between M-S
	EEPROM R/W Fail	EEPROM R/W Fail
	Relay-Check Fail	Relay-Check Fail
	DC Injection High	DC Injection High
	The result of Auto Test Function is fail	The result of Auto Test Function is fail
	DC bus is too high	DC bus is too high
	The voltage reference inside is abnormal	The voltage reference inside is abnormal
	AC HCT Failure	AC HCT Failure
	GFCI Device Failure	GFCI Device Failure
	Device fault	Device fault

	M-S Version Unmatched	M-S Version Unmatched
	Fac Failure:Fac Out of Range	Fac Failure:Fac Out of Range
	AC Voltage Out of Range	AC Voltage Out of Range
	Utility Loss	Utility Loss
	GFCI Failure	GFCI Failure
	PV Over Voltage	PV Over Voltage
	Isolation Fault	Isolation Fault
	Fan Lock	Fan Lock
	Over Temperature in Inverter	Over Temperature in Inverter
	Consistent Fault:Vac differs for M-S	Consistent Fault:Vac differs for M-S
	Consistent Fault:Fac differs for M-S	Consistent Fault:Fac differs for M-S
	Ground I differs for M-S	Ground I differs for M-S
	DC inj. differs for M-S	DC inj. differs for M-S
	Consistent Fault:Fac, Vac Differs for M-S	Consistent Fault:Fac, Vac Differs for M-S
	High DC Bus	High DC Bus
Flash	Flashing	Update inverter

About the further information for each fault, please reference to Chapter “10.TROUBLESHOOTING”.

8. MONITORING SYSTEM

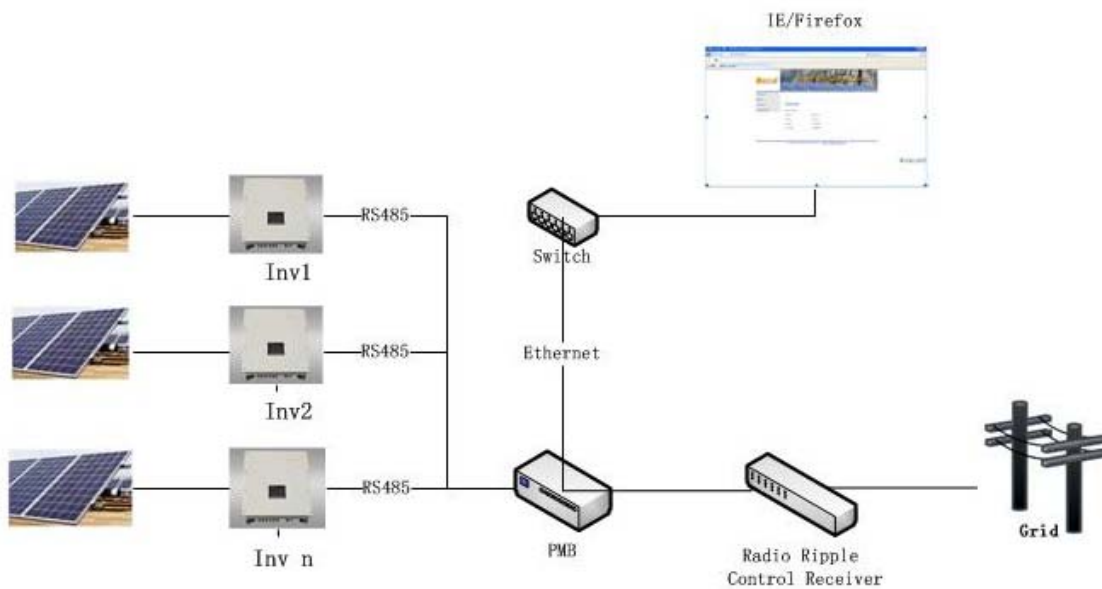

- System configuration:

The system consists of Grid、Radio Ripple Control receiver、PMB、Inverter、Battery pack and so on(view picture above for reference).

- Introduction of sub-element:

1. PMB (Power Management Box) is core of the system. It's used for managing power and monitoring working status of inverter.
2. Radio Ripple Control Receiver receives managing instruction of power from grid operations, and output digital switch amount to PMB. Then PBM work on the output and send managing instruction of power to inverter.

3. IE/Firefox is a web browser for PC, through which people can check PMB's built-in webpage. The webpage can clearly monitor inverter's operating data. It can also be configured with PMB's power management function.

- Working principle of the system:

The omnisol inverter can be connected to the PMB (Power Management Box) via its RS485 interface, the maximum of the quantity is 20 sets three-phase inverter.

Inside the PMB, a web server is integrated in, customers can view or check the detailed information about their inverter by login on a IP address of PMB, (for example: <http://192.168.16.48/index.asp>), the information including but not limited to total quantity of the inverters, gross generation, generation for today, as well as all the parameters of each inverter like voltage, current and frequency etc.

Meanwhile, the PMB can receive the signal from the local power grid via a Radio Ripple Control Receiver, therefore to archive the active power/reactive power compensation function for the inverter.

9. RECYCLING AND DISPOSAL

To comply with European Directive 2002/96/EC on waste Electrical and Electronic Equipment and its implementation as national law, electrical equipment that has reached the end of its life must be collected separately and returned to an approved recycling facility. Any device that you no longer required must be returned to your dealer or you must find an approved collection and recycling facility in your area.

Ignoring this EU Directive may have severe affects on the environment and your health.



WARNING



This device SHALL NOT be disposed of in residential waste.

10. TROUBLESHOOTING

	LCD display	Possible actions
Resumable Fault	Isolation Fault	<ol style="list-style-type: none"> 1. Check the impedance between PV (+) & PV (-) and the inverter is earthed. The impedance must be greater than 2.4MΩ. 2. Check whether the AC-side has contacts with earth.
	Ground I Fault	<ol style="list-style-type: none"> 1. The ground current is too high. 2. After cut off the AC side connection, unplug the inputs from the PV generator and check the peripheral AC system. 3. After the cause is cleared, re-plug the PV panel and AC connection, and check PV-Inverter status.
	Grid Fault Fac Failure:Fac Out of Range AC Voltage Out of Range	<ol style="list-style-type: none"> 1. Wait for a moment, if the grid returns to normal, PV-Inverter automatically restarts. 2. Make sure grid voltage and frequency meet the specifications.
	Utility Loss	<ol style="list-style-type: none"> 1. Grid is not connected. 2. Check grid connection cables. 3. Check grid usability. 4. If grid is ok, and the problem persists, maybe the fuse in the inverter is open, please call service.
	Over Temperature in Inverter	<ol style="list-style-type: none"> 1. The internal temperature is higher than specified normal value. 2. Find a way to reduce the ambient temperature. 3. Or move the inverter to a cooler environment.
	PV Over Voltage	<ol style="list-style-type: none"> 1. Check the open PV voltage, see if it is greater than or too close to 1000VDC (for Omniksol-13k-TL or Omniksol-17k-TL or Omniksol-20k-TL). 2. If PV voltage is less than 1000VDC, and the problem still occurs, please call local service.
	Permanent Fault	<p>Consistent Fault: Fac differs for M-S Vac differs for M-S Fac, Vac Differs for M-S Ground I differs for M-S</p> <p>Disconnect PV (+) or PV (-) from the input, restart the inverter.</p>

DC inj. differs for M-S	
AC Relay Check Fail	<ol style="list-style-type: none"> 1. Disconnect ALL PV (+) or PV (-). 2. Wait for a few seconds. 3. After the LCD switches off, reconnect and check again. 4. If the problems remain please call local service.
High DC bus	
DC Injection High	
EEPROM R/W Fail	
Fan Lock	
M-S Version Unmatched	
SPI Failure:Communication Fails between M-S	
AC HCT Fault	
<i>GFCI Device Failure</i>	

11. WARRANTY

Dear Customer:

Thanks for choosing Omnik products.

The warranty period for inverter is 60 months as standard, starting from the date of the purchase invoice date marked.

- Terms and Conditions

Omnik offers 60 months from the date of purchase from retailer for Omniksol-13k-TL / 17k-TL / 20k-TL on-grid inverters, subject to the conditions listed below. Please note that this does not apply for the accessories. If a product is suspected of being defective during the specified Omnik factory warranty period then Omnik will initially perform a pre-qualification of the issue.

If a product is determined to be defective then Omnik will appoint a local installer who will conduct:

- On-site inspection & repair or;
- Exchange for same or similar replacement product

In the latter case, the remainder of the warranty entitlement will be transferred to the repaired or replacement product. In such an event, you do not receive a new certificate, as your entitlement is documented at Omnik.

- Exclusion of Liability

Circumstances where warranty is not provided

Inverter damaged during transportation, installation, usage, connection, non compliance with the instruction manual or other man-made damage

Operate the products beyond the applicable safety regulations

The warranty card has been altered or its date is hard to recognize

Change, modification of repair attempts of the product without authorization

Product description nonconformity from the content of warranty card

Information on the original nameplate missing or not clear enough to identify the delivery date and product model

Use non-designed accessories

Improper PV system design

Force majeure(e.g. lightning, earthquake, flood or fire)

Cosmetic changes to the unit from environmental conditions or accidents

From the day the inverter is purchased, please correctly fill in the Warranty Card and submit to the appointed installers to sign/stamp and date. Any changes need to be made by the appointed installers. Please keep good custody of your Warranty Card and present it when you need the warranty service and keep the record provided by the service staff.

12. ABBREVIATION

LCD	Liquid Crystal Display
LED	Light Emitting Diode
MPPT	Maximum Power Point Tracking
PV	Photovoltaic
Vdc	Voltage at the DC side
Vac	Voltage at the AC side
Vmpp	Voltage at the Maximum Power Point
Impp	Amperage at Maximum Power Point
AC	Alternating Current (Form of electricity supplied by Utility Company)
DC	Direct Current (Form of electricity generated by PV modules)
VDE 0126-1-1	German standards for establishing suitability for Grid Connection of the Inverter.
DC Switch	Switch in the DC Circuit. Disconnects DC source from Inverter. May be integrated or external to Inverter.

13. CONTACT

Suzhou Headquarter

Xinghu Road No.218 bioBAY Park A4-314 215123 Suzhou China

Tel: +86 512 6295 6676

Fax: +86 512 6295 6682

Email: info@omnik-solar.com

www.omnik-solar.com

Omnik German Service Center

An der Pikardie 6

01277 Dresden

Deutschland

Tel: +49 (0)351 30986031

Fax: +49 (0)351 30930022

Email: service-de@omnik-solar.com

Service line

Tel: +86 512 6295 6676

Fax: +86 512 6295 6682

Email: service@omnik-solar.com

